

**LEGEND**

- CITY OF TORONTO STANDARD CONCRETE PAVING WITH GRANITE PAVES BAND OF COLOR
- GRANITE PAVING
- CITY OF TORONTO STANDARD PRECAST CONCRETE PAVING WITH GRANITE PAVES BAND OF COLOR
- PRECAST CONCRETE PAVING
- BENCHES
- PLANTER POT WITH SEASONAL PLANTING
- PLANT POT WITH SEASONAL PLANTING (FUTURE)
- PARK BENCH

NOTE: ALL PLANTINGS TO BE PROVIDED BY CONTRACTOR. ALL PLANTINGS TO BE PROVIDED BY CONTRACTOR. ALL PLANTINGS TO BE PROVIDED BY CONTRACTOR.

no.	revision	date	by
05	ISSUED FOR SPA	2019-08-22	AF
04	ISSUED FOR REZONING/SPA	2019-03-28	AF
03	ISSUED FOR REZONING/SPA	2018-12-17	AF
02	ISSUED FOR REZONING/SPA	2018-03-23	AF
01	ISSUED FOR REVIEW	2018-03-16	AF

CONTRACTOR MUST VERIFY ALL DIMENSIONS ON THE JOB AND REPORT ANY DISCREPANCY TO THE LANDSCAPE ARCHITECT BEFORE PROCEEDING WITH THE WORK. ALL DRAWINGS AND SPECIFICATIONS ARE INSTRUMENTS OF SERVICE AND THE PROPERTY OF THE LANDSCAPE ARCHITECT WHICH MUST BE RETURNED AT THE COMPLETION OF THE WORK. ALL DRAWINGS TO BE USED FOR CONSTRUCTION ONLY WHEN SIGNED BY THE LANDSCAPE ARCHITECT.

signed \_\_\_\_\_ date \_\_\_\_\_

**STUDIO tla**  
 20 Champain Blvd. Suite 102 - Toronto ON - M3H 2Z1 info@terraplan.ca www.terraplan.ca

**METROPIA**  
**CAPITAL DEVELOPMENTS**  
**RIO CAN LIVING**

CLIENTS  
 11 YORKVILLE AVENUE  
 TORONTO, ONTARIO

PROJECT  
 LANDSCAPE PLAN

DRAWING  
 DRAWN: AF  
 CHECKED: JC  
 SCALE: AS SHOWN  
 DATE: 2019-08-22  
 PROJECT NO.: 17-177

LS-100  
 SHEET NO.

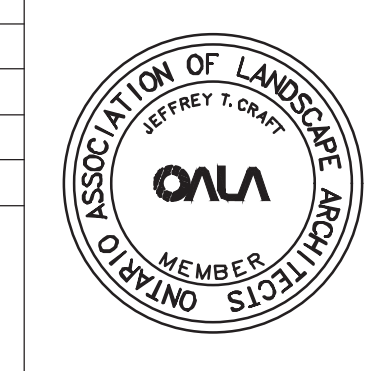





no.	revision	date	by
05	ISSUED FOR SPA	2019-08-22	AF
04	ISSUED FOR REZONING/SPA	2019-03-28	AF
03	ISSUED FOR REZONING/SPA	2018-12-17	AF
02	ISSUED FOR REZONING/SPA	2018-03-23	AF
01	ISSUED FOR REVIEW	2018-03-16	AF

CONTRACTOR MUST VERIFY ALL DIMENSIONS ON THE JOB AND REPORT ANY DISCREPANCY TO THE LANDSCAPE ARCHITECT BEFORE PROCEEDING WITH THE WORK.  
 ALL DRAWINGS AND SPECIFICATIONS ARE INSTRUMENTS OF SERVICE AND THE PROPERTY OF THE LANDSCAPE ARCHITECT WHICH MUST BE RETURNED AT THE COMPLETION OF THE WORK.  
 ALL DRAWINGS TO BE USED FOR CONSTRUCTION ONLY WHEN SIGNED BY THE LANDSCAPE ARCHITECT.

signed \_\_\_\_\_ date \_\_\_\_\_



20 Champlain Blvd. Suite 102 - Toronto ON - M3H 2Z1 info@terraplan.ca www.terraplan.ca



CLIENTS

11 YORKVILLE AVENUE  
TORONTO, ONTARIO

PROJECT  
3RD FLOOR OUTDOOR AMENITY PLAN

DRAWING  
 DRAWN: AF  
 CHECKED: JC  
 SCALE: AS SHOWN  
 DATE: 2019-08-22  
 PROJECT NO.: 17-177



SHEET NO. LS-101







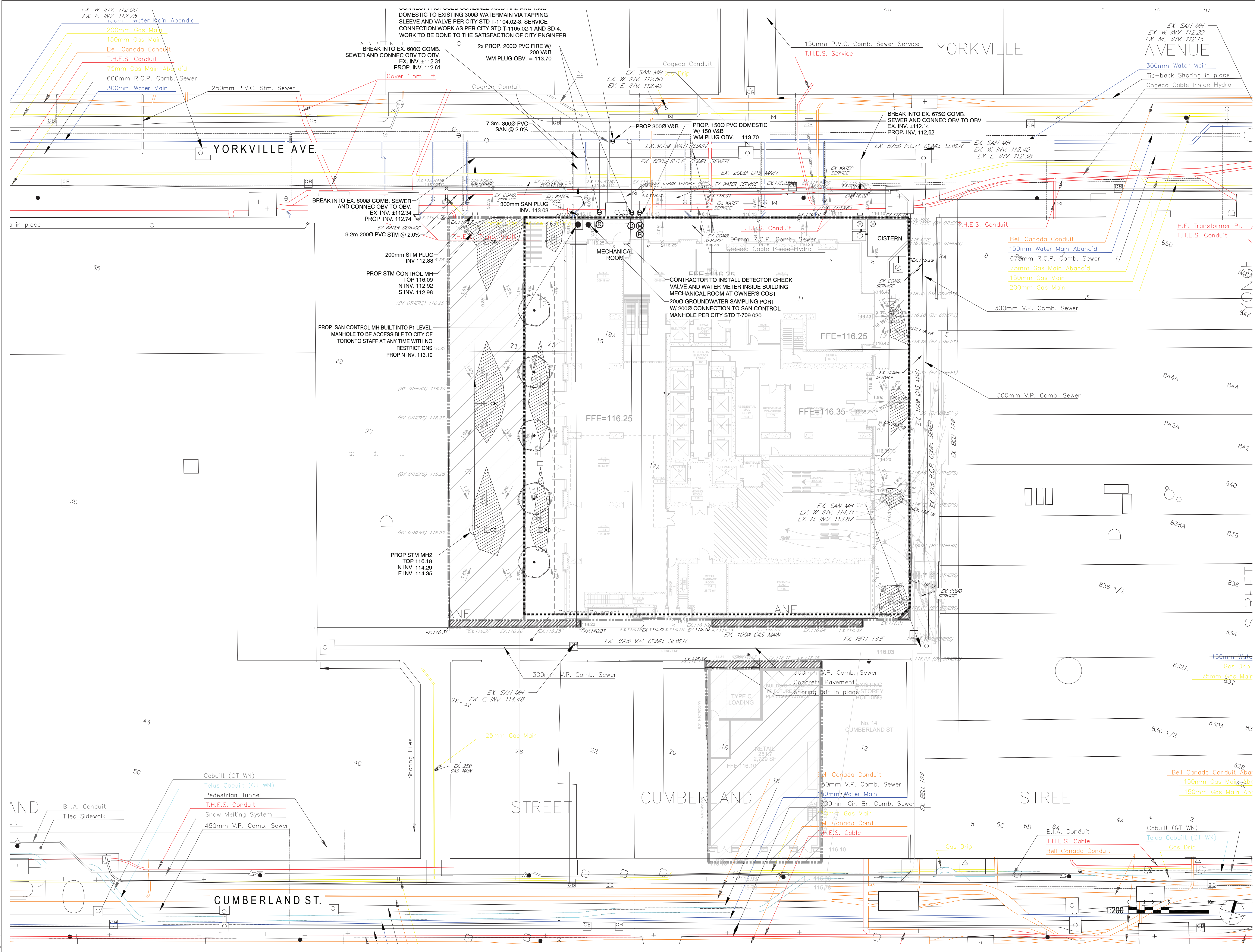

no.	revision	date	by
05	ISSUED FOR SPA	2019-08-22	AF
04	ISSUED FOR REZONING/SPA	2019-03-28	AF
03	ISSUED FOR REZONING/SPA	2018-12-17	AF
02	ISSUED FOR REZONING/SPA	2018-03-23	AF
01	ISSUED FOR REVIEW	2018-03-16	AF

CONTRACTOR MUST VERIFY ALL DIMENSIONS ON THE JOB AND REPORT ANY DISCREPANCY TO THE LANDSCAPE ARCHITECT BEFORE PROCEEDING WITH THE WORK.  
 ALL DRAWINGS AND SPECIFICATIONS ARE INSTRUMENTS OF SERVICE AND THE PROPERTY OF THE LANDSCAPE ARCHITECT WHICH MUST BE RETURNED AT THE COMPLETION OF THE WORK.  
 ALL DRAWINGS TO BE USED FOR CONSTRUCTION ONLY WHEN SIGNED BY THE LANDSCAPE ARCHITECT.

signed \_\_\_\_\_ date \_\_\_\_\_

**STUDIO tla**  
 20 Champian Blvd. Suite 102 - Toronto ON - M3H 2Z1 info@terraplan.ca www.terraplan.ca

**METROPIA**  
**CAPITAL DEVELOPMENTS**  
**RIO CAN LIVING**

CLIENTS  
 11 YORKVILLE AVENUE  
 TORONTO, ONTARIO

PROJECT  
 COMPOSITE UTILITIES PLAN

DRAWING  
 DRAWN: AF  
 CHECKED: JC  
 SCALE: AS SHOWN  
 DATE: 2019-08-22  
 PROJECT NO: 17-177

LS-200  
 SHEET NO.

August 22, 2019 1:08 PM I:\01-PROJECTS\2017\17-177-11 YORKVILLE\01-CADD\CURRENT\0105-SPALS-100-LANDSCAPE PLANS.DWG



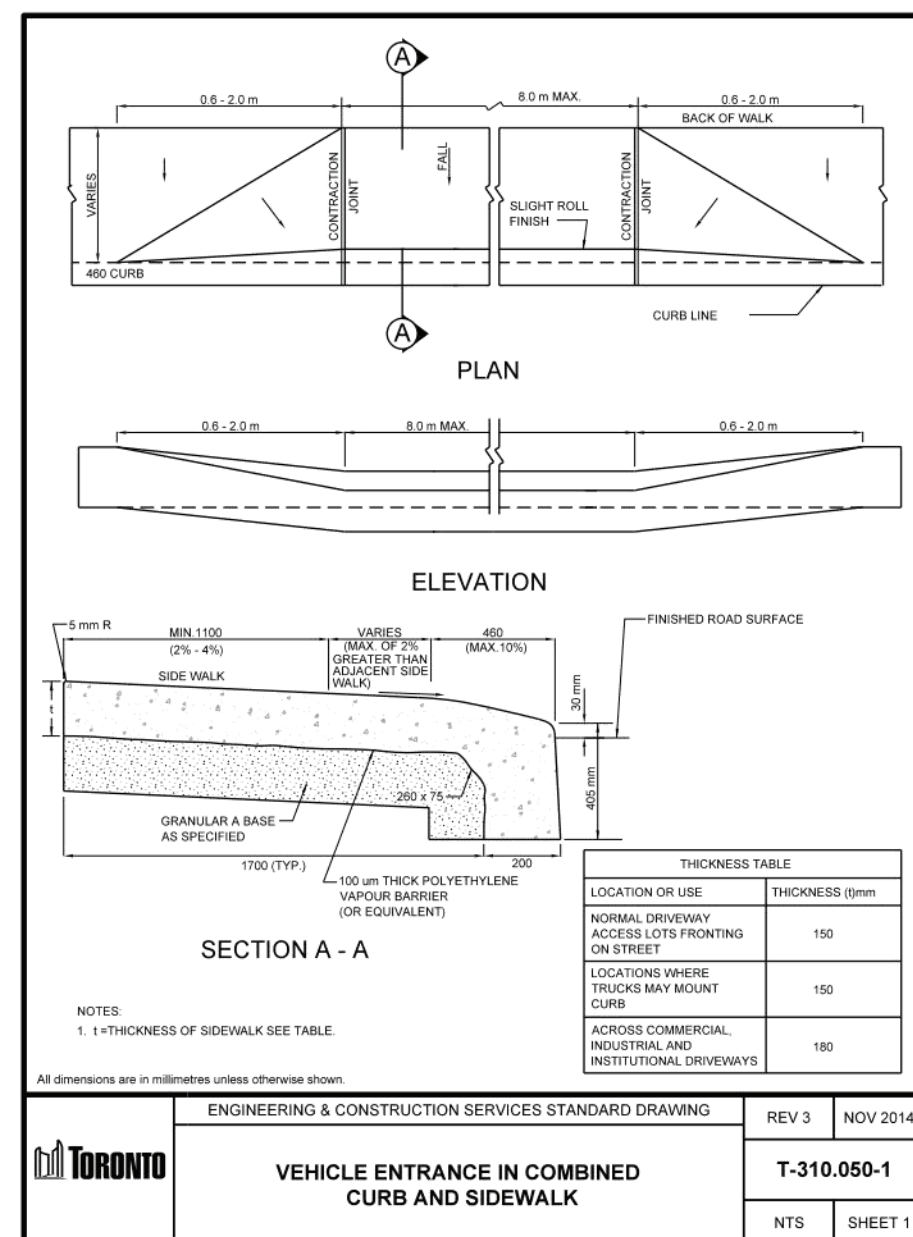

1 T-310.050-1

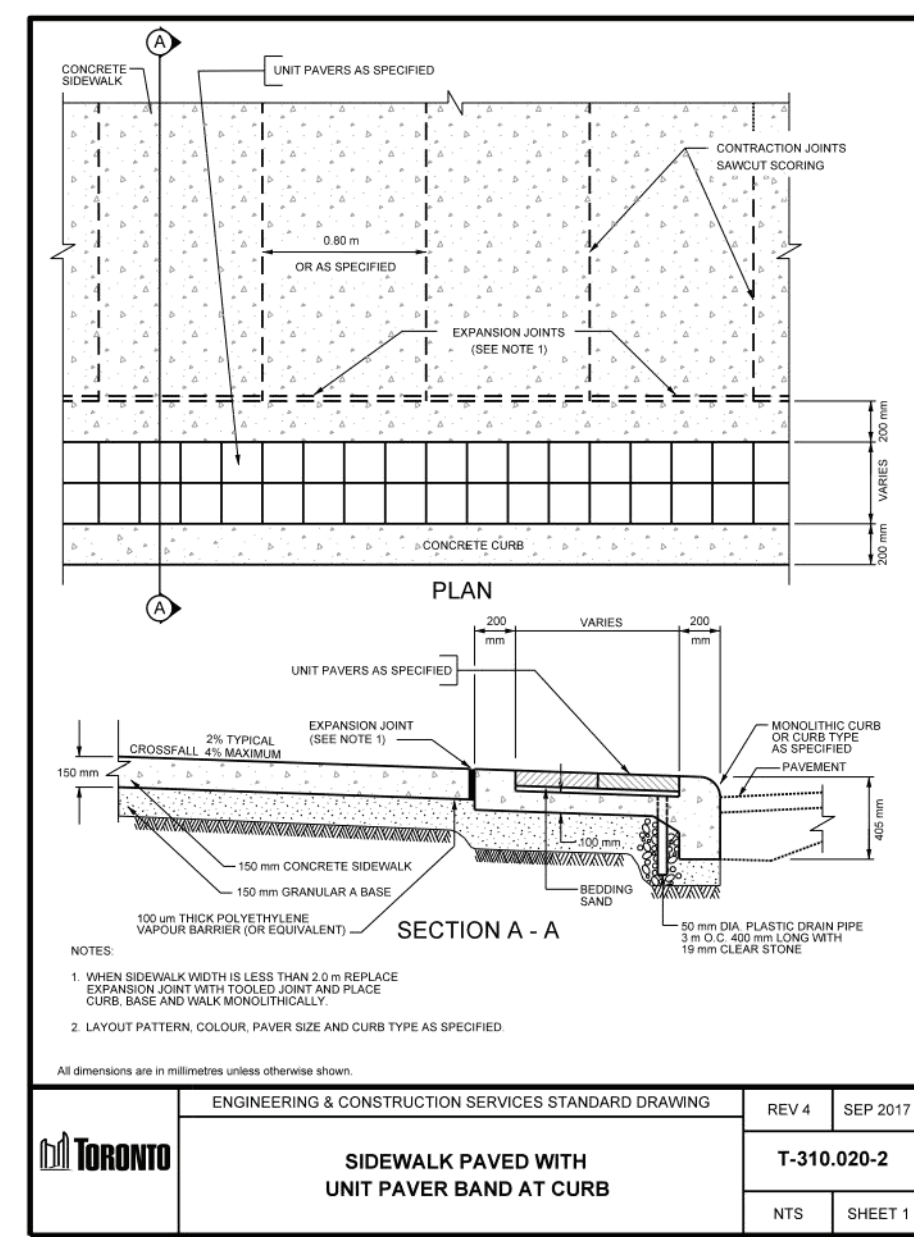

2 T-310.020-2

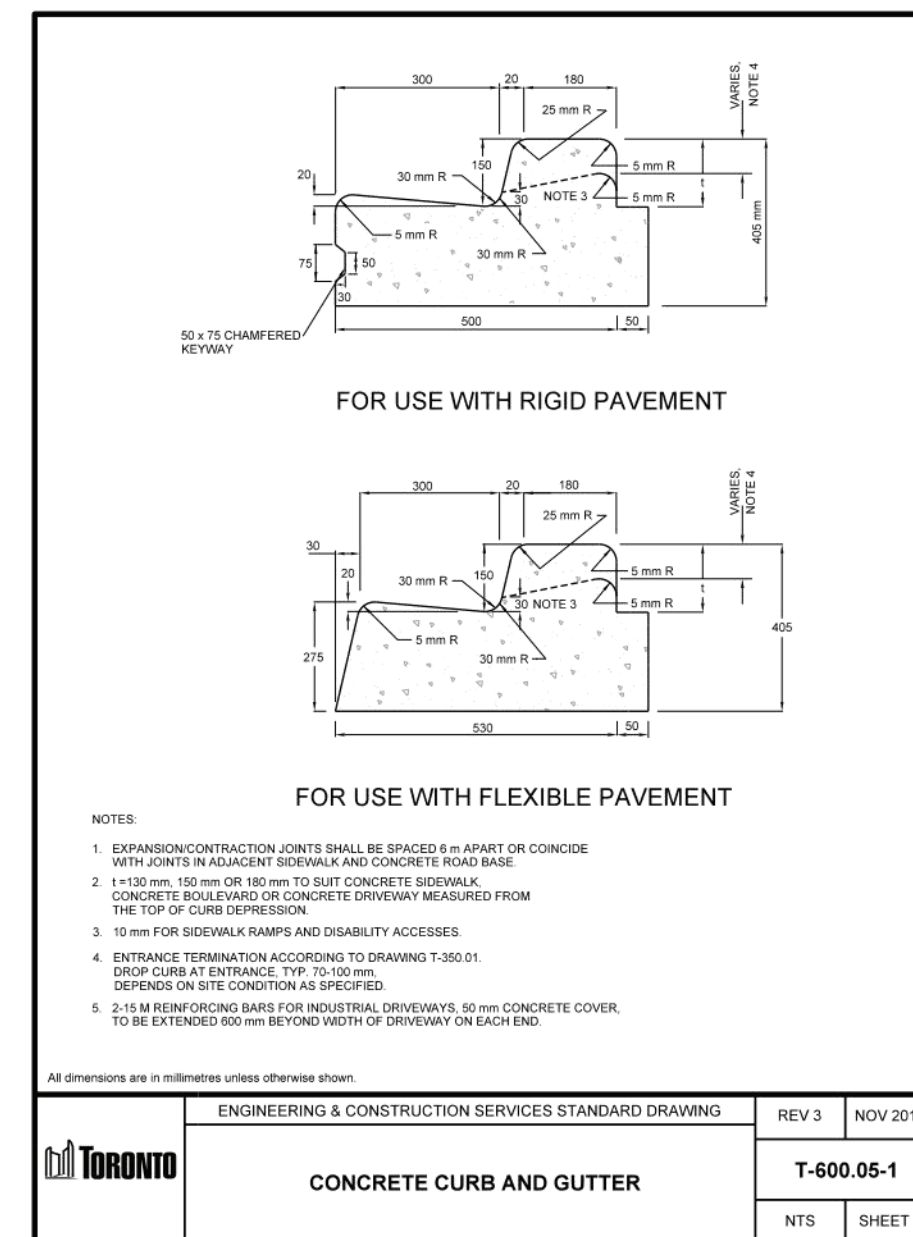

3 T-600.05-1

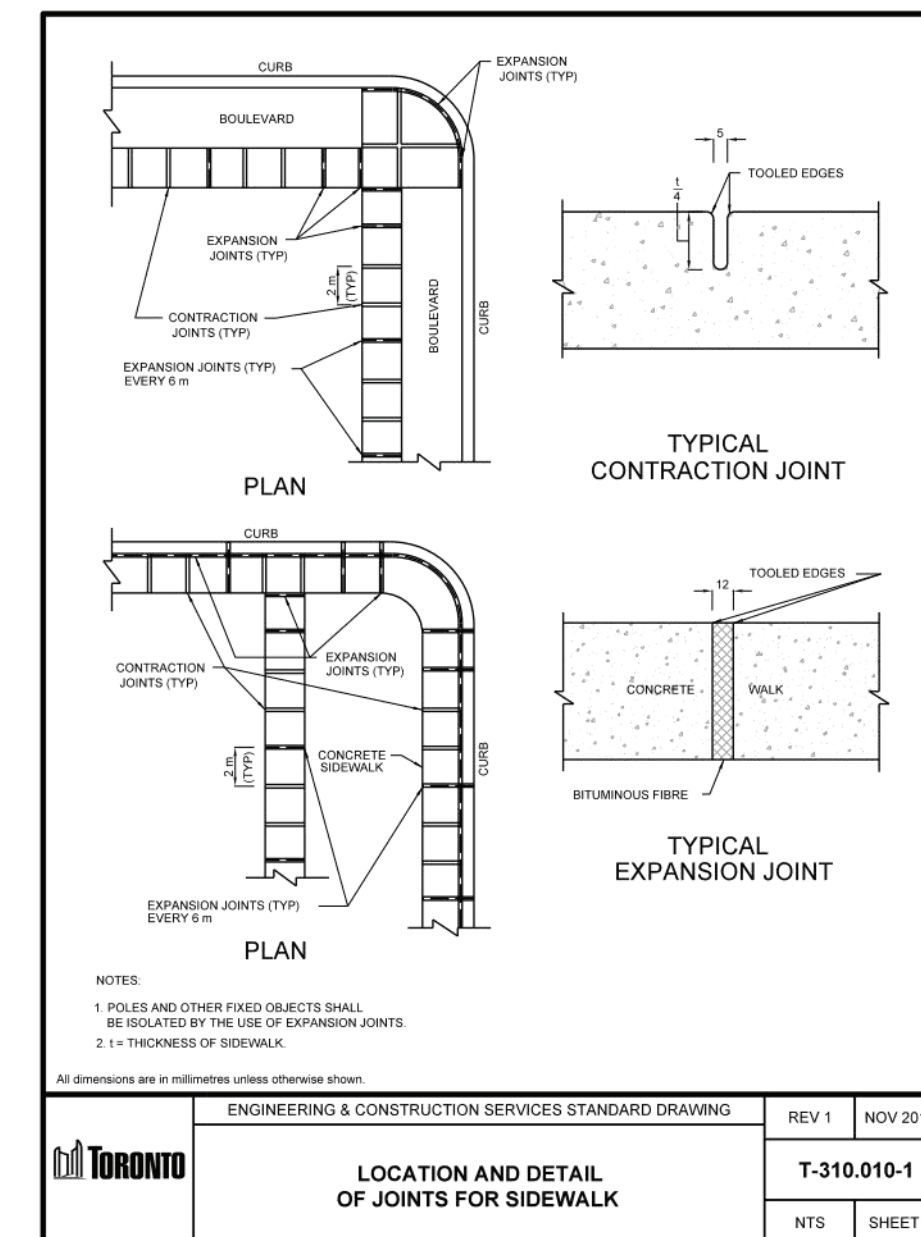

4 T-310.010-1

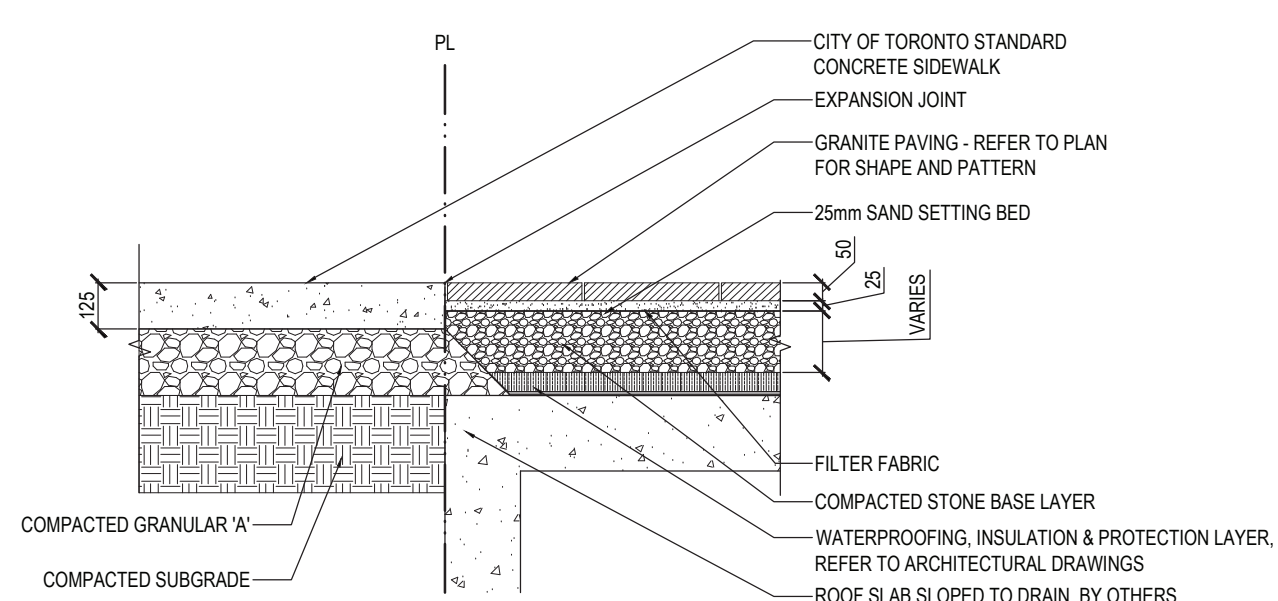

5 PAVING DETAIL ON/OFF SLAB SCALE=1:20

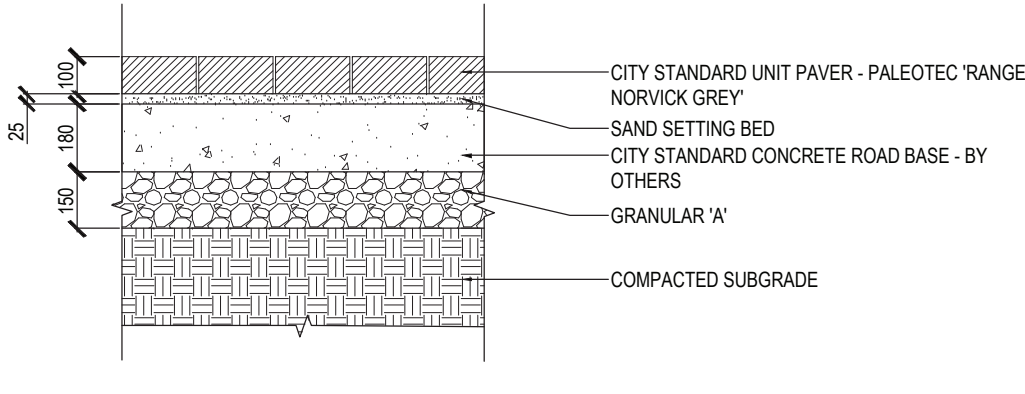

6 CITY STANDARD VEHICULAR UNIT PAVER SCALE=1:20



DOG WASTE STATION (400 MUTT MITT SINGLES)  
ITEM # 1006/1007  
COLOUR: BLACK/WHITE  
BY MUTT MITT OR APPROVED EQUAL.

MANUFACTURER:  
MUTT MITT  
12316 WORLD TRADE DRIVE  
STE 102  
SAN DIEGO, CA 92128  
PH: 800-697-6064  
FAX: 659-698-5511  
EMAIL: INFO@MUTTMITT.COM

7 MUTT MITT BAG STATION N.T.S.

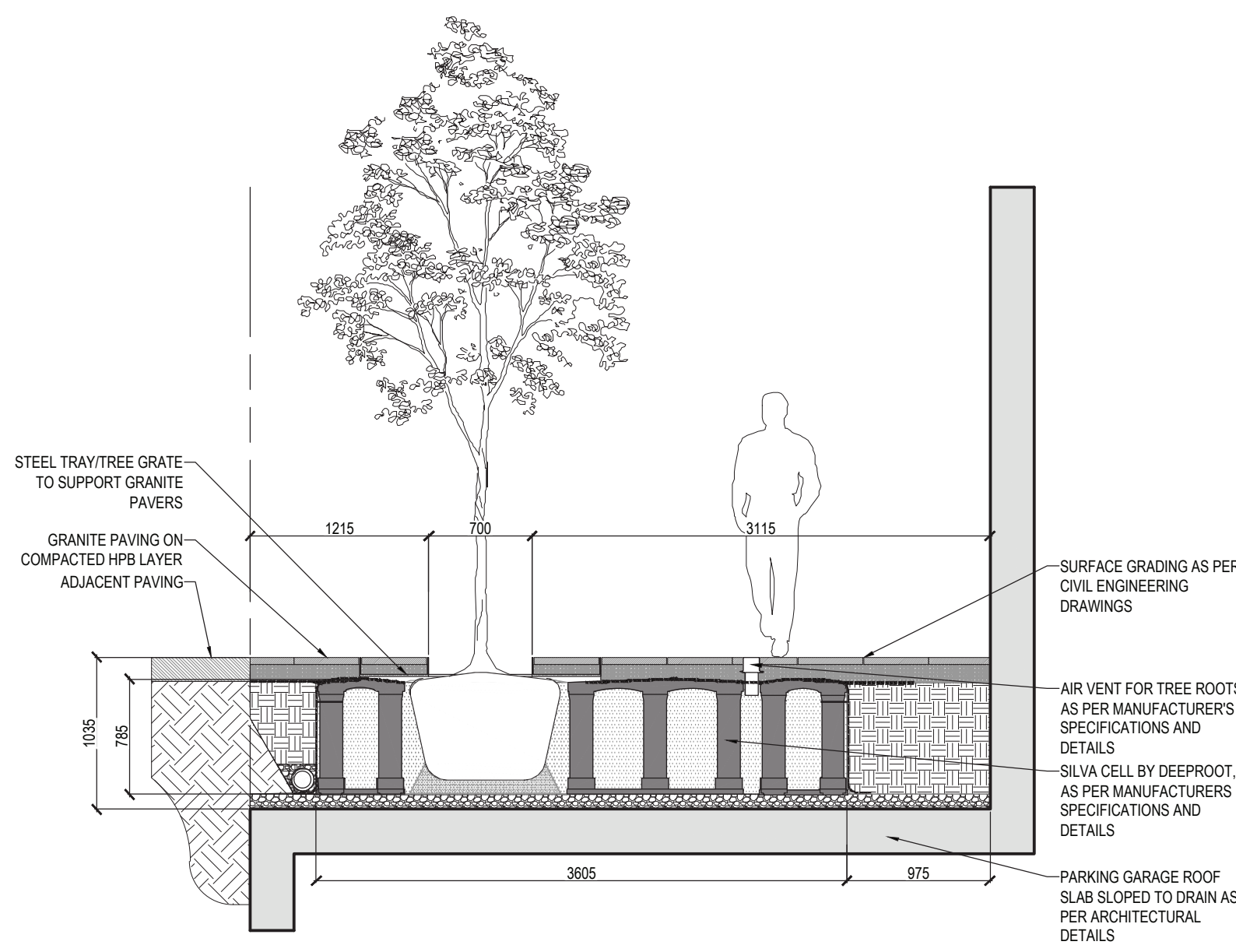

8 SOIL CELL SECTION SCALE=1:40

no.	revision	date	by
05	ISSUED FOR SPA	2019-08-22	AF
04	ISSUED FOR REZONING/SPA	2019-03-28	AF
03	ISSUED FOR REZONING/SPA	2018-12-17	AF
02	ISSUED FOR REZONING/SPA	2018-03-23	AF
01	ISSUED FOR REVIEW	2018-03-16	AF

CONTRACTOR MUST VERIFY ALL DIMENSIONS ON THE JOB AND REPORT ANY DISCREPANCY TO THE LANDSCAPE ARCHITECT BEFORE PROCEEDING WITH THE WORK.  
ALL DRAWINGS AND SPECIFICATIONS ARE INSTRUMENTS OF SERVICE AND THE PROPERTY OF THE LANDSCAPE ARCHITECT WHICH MUST BE RETURNED AT THE COMPLETION OF THE WORK.  
ALL DRAWINGS TO BE USED FOR CONSTRUCTION ONLY WHEN SIGNED BY THE LANDSCAPE ARCHITECT.

signed \_\_\_\_\_ date \_\_\_\_\_



20 Champian Blvd. Suite 102 - Toronto ON - M3H 2Z1 info@terraplan.ca www.terraplan.ca



CLIENTS

11 YORKVILLE AVENUE  
TORONTO, ONTARIO

PROJECT LANDSCAPE DETAILS

DRAWING	AF
CHECKED:	JC
SCALE:	AS SHOWN
DATE:	2019-08-22
PROJECT NO.:	17-177



LD-100 SHEET NO.